



Zoning Staff Report

Date: February 8, 2022

Case Number: ZC-21-140

Council District: 9

Conditional Use Permit

Case Manager: [Beth Knight](#)

Owner / Applicant: DD White Settlement Property, LLC/ Jacob Petrie

Site Location: 3201 White Settlement Road

Acreage: 0.50 acres

Request

Proposed Use: Car Wash

Request: From: "E" Neighborhood Commercial

To: Add Conditional Use Permit (CUP) to allow a self-serve carwash facility in "E" Neighborhood Commercial; site plan included, with specific regulations for setbacks, fencing location, parking, and landscaping, site plan included

Land Use Compatibility: Requested change is **not compatible**.

Comprehensive Plan Consistency: Requested change is **not consistent (Significant Deviation)**.

Staff Recommendation: **Denial**

Zoning Commission Recommendation: **Denial by a vote of 9-0**

Table of Contents

1. [Project Description and Background](#)
2. [Surrounding Zoning and Land Uses](#)
3. [Recent Zoning History](#)
4. [Public Notification](#)
5. [Development Impact Analysis](#)
 - a. [Land Use Compatibility](#)
 - b. [Comprehensive Plan Consistency](#)
 - c. [Economic Development Plan](#)
6. Area Zoning Map with 300 ft. Notification Area
7. Site Plan
8. Area Map
9. Future Land Use Map
10. Aerial Photograph

Project Description and Background

The proposed site is located at the southwest corner of White Settlement Road and Blanch Circle, west of University Drive. The applicant is requesting to add a Conditional Use Permit to allow a self-serve carwash facility; site plan included.

Carwashes are only permitted within commercial zoning districts through the CUP process. The applicant has applied for the (CUP) Conditional Use Permit to allow this use within the “E” district for a drive-thru carwash facility in an approximately 3,500 sq. ft. building. Self-service vacuum spaces are shown in two rows south of the carwash building. Conditional uses are those uses which are generally compatible with the permitted land uses in a given zoning district, but which require individual review of their proposed location, design and configuration, and the imposition of conditions in order to ensure the appropriateness of the use at a particular location.

The general area and the subject site are designated as Mixed Use in the Cultural District Growth Center. Supporting denser mixed-uses is a Trinity Metro bus line that runs immediately to the east along Blanch Circle. Two additional bus routes run approximately ½ mile to the south along W. 7th Street. White Settlement is covered by a Scenic Corridor overlay.

While a carwash is not permitted in the “E” zoning district by right, allowing one by CUP with a site plan may help mitigate any neighborhood concerns, as well as give options for the CUP to be revoked in the event of code violation convictions. The site is currently vacant land. The nearest residential “C” district lies along the southern property line, with additional multifamily complexes to the south and southwest. Because the site is directly adjacent to a multifamily residential use, the closest residential building is approximately 20 feet away. The car wash dryer faces other commercial uses to the east. Because sound volume does not decrease noticeably until after 300 feet to approximately 60 decibels, the location of the car wash equipment and 11 vacuums are likely to have a detrimental impact on the neighborhood. No noise mitigation measures are shown.

The site plan shows a fence 5 feet from the southern property line, which places the landscaping area between the car wash and the apartment complex’s fences. Landscaping shaded by two solid fences will not get enough light to grow. The ½-acre lot size has only the minimum distance for the car wash building and vacuums required from a residential use. The small size of the lot does not support an auto-oriented use, as the staff parking is shown as part of the vacuuming spaces and the driveways are approximately 10 feet from the intersection or another driveway. While the redesigned site plan has fewer development waivers than the original site plan, the screening fence location, less landscaping along White Settlement, and fewer parking spaces provided are new or more significant development waivers than originally proposed.

Through Ordinance 23609 effective March 29, 2019, the Conditional Use Permit allows for an unlimited time period for the operation of a use unless otherwise approved by the City Council. If a time limit is established for a Conditional Use Permit, the renewal of the CUP shall be considered through the public hearing process and approved by the City Council. A CUP shall expire if no permitting action is taken within six months of approval or cease of the use for six months. A CUP may be revoked through the public hearing process if necessary after convictions of one or more code violations.

Per Section 4.407 (a), the following general rules apply to all conditional uses:

- a) Conditional use permits in residential districts shall be limited to those uses designated “CUP” in the Residential District Use Table in Chapter 4, Article 6, Section 4.603.

- b) Approval of a conditional use permit shall authorize only the particular use or category of related uses for which the conditional use permit is issued.
- c) A conditional use shall not be enlarged, extended or otherwise modified unless approved by the City Council or approved administratively as applicable.
- d) The use of property for the purposes described in a conditional use permit shall not commence until a certificate of occupancy has been issued. A certificate of occupancy shall not be issued until all or approvals which may be required by the Codes and Ordinances of the City, including, but not limited to, a Building Permit, a Certificate Of Occupancy and subdivision approval have been satisfied.

Section (d) provides the following Conditional Use Permit factors in consideration of appropriateness of a request:

- a) The proposed use is consistent with the Comprehensive Plan;
- b) The proposed use is compatible with the existing and adjacent uses.
- c) The proposed use meets all supplemental use standards specifically applicable to the use as set forth in Chapter 5;
- d) The proposed use is compatible with and preserves the character and integrity of adjacent development and neighborhoods;
- e) The proposed use is not materially detrimental to the public health, safety, and welfare, or results in material damage or prejudice to other property in the vicinity.

Below is a chart that illustrates the differences between the base E regulation and the proposed CUP:

Requirement	E Standards	Proposed CUP
Street setbacks	20-foot front setbacks are required on all non-arterial street sides in E zoning.	Payment kiosk and canopy are in eastern setback <i>(requires Development Regulation Waiver)</i>
Solid screening fence	6-ft minimum solid screening fence is required along the southern property line, which abuts a residential district	Screening fence is 5 feet away from property line, instead of along it <i>(requires Development Regulation Waiver)</i>
Parking spaces	5 parking spaces are required for each car length in car wash	Less than 4 parking spaces are shown for 3 lengths in carwash <i>(requires Development Regulation Waiver)</i>
Landscaping	75% of site's required landscaping is to be in front of the building	Less than 50% of site's required landscaping is in front of the building <i>(requires Development Regulation Waiver)</i>

Surrounding Zoning and Land Uses

- North "E" Neighborhood Commercial / Cemetery
- East "F" General Commercial and "PD 174" Planned Development for "E" uses plus automobile sales and rental / Automobile sales
- South "C" Medium Density Multifamily / Multifamily uses
- West "E" Neighborhood Commercial / Photography studio and vacant land

Recent Zoning History

ZC-17-170, subject, from E to PD for E uses to add auto storage, approved 10/19/2017.
ZC-18-154, subject, from PD for E uses with auto storage to E, approved 11/14/2018.

Public Notification

300-foot Legal Notifications were mailed on August 23, 2021.

The following organizations were notified: (emailed August 23, 2021)

Organizations Notified	
West 7th Neighborhood Alliance	Westside Alliance
Casa Blanca HOA	Sixth & Arch Adams HA
Monticello NA	Crestwood NA
Linwood NA*	Tarrant Regional Water District
Streams and Valleys Inc	Trinity Habitat for Humanity
Cultural District Alliance	Fort Worth ISD

* *This Neighborhood Association is located closest to the subject property.*

Development Impact Analysis

Land Use Compatibility

The applicant is proposing a zoning change to add a CUP to allow a carwash facility in the “E” zoning district. Surrounding land uses consist of multifamily complexes to the south with other commercial uses or commercially zoned vacant land in all other directions. The multifamily uses are immediately adjacent to the southern property line.

The site plan as submitted is not in general compliance with the Zoning Ordinance regulations.

1. All non-arterial street setbacks are required to be 20 feet, as per Sec. 4.901. The pay stations encroach into the eastern setback. **These items need development waivers as shown.**
2. A 6-ft minimum solid screening fence is required **along** the southern property line – instead of 5 feet away, which abuts a residential district, as required in Sec. 5.108. **This item needs a development waiver as shown.** Either add this note in bold or revise the site plan.
3. 15 parking spaces are required for 3 car lengths in the car wash, instead of 11 parking spaces provided, as required in Sec. 5.108. **This item needs a development waiver as shown.**
4. The site is required to have 1,722 square feet of landscaping in front of the building, instead of the 1,150 square feet shown. **This item needs a development waiver as shown.**
5. Landscaping along the southern property line sandwiched between two solid fences will not get enough light to grow, causing the site to effectively have no landscaping adjacent to the residential use. **This item needs a development waiver as shown.** Either add this note in bold or revise the site plan.
6. Northeastern drive is likely too close to the intersection. The northwestern driveway is likely too close to the driveway on the adjacent lot to the west.
7. Note the land use of the surrounding properties.

8. Lighting adjacent to parking space #1 needs to be rotated to not face or shine on the adjacent residential property.
9. Dumpster enclosure solid walls and gate needs to be noted.
10. It appears the northeastern driveway will allow access to the car wash without paying first.
11. Change the note to “will comply with Sec. 6.301 Landscaping, with exception of the development waiver noted above”.
12. Window material noted as “translucent”. Should it be “transparent”? Car washes should have durable exterior surfaces, as per Sec. 5.108.

The proposed zoning request **is not compatible** with surrounding land uses due the lack of sound buffering, as well as the small lot size that does not provide sufficient space to implement minimum zoning requirements, requiring notable development waivers.

(Comments made by Platting (Subdivision Ordinance), Transportation/Public Works, Fire, Park & Recreation, and Water Department staff cannot be waived through the Zoning Commission and City Council. Approval of the zoning site plan does not constitute the acceptance of conditions.)

Comprehensive Plan Consistency – Arlington Heights

The 2021 Comprehensive Plan currently designates the subject property as mixed use in the Cultural District Growth Center, where vehicular uses are generally not allowed. The proposed zoning is inconsistent with the land use designations for this area, and conflicts with the following policies of the Comprehensive Plan:

- Accommodate higher density residential and mixed uses in transit-oriented developments, urban villages, and designated mixed-use growth centers.
- Locate multifamily units within walking distance of public transportation, employment, recreation, and/or shopping to increase accessibility and decrease vehicular traffic.
- Promote appropriate infill development of vacant lots, old commercial centers (greyfields), and contaminated sites (brownfields) within developed areas, particularly in the central city.
- Support zoning changes that accommodate multifamily residential development within urban villages, transit-oriented developments (TOD) and designated growth centers.
- Separate incompatible land uses with buffers or transitional uses. Some land uses have attributes such as height, proportion, scale, operational characteristics, traffic generated, or appearance that may not be compatible with the attributes of other uses.
- Promote commercial and urban residential development within the Cultural District and Clear Fork Mixed-Use Growth Centers.
- Encourage urban residential development in appropriate locations to create more walkable, pedestrian-oriented neighborhoods.

Based on a lack of conformance with the future land use map and the policies stated above, the proposed zoning is **not consistent** with the Comprehensive Plan. (Significant Deviation)

Economic Development Plan

The 2021 Economic Development Strategic Plan identified four different results to facilitate the success and growth of Fort Worth:

1. High-wage job growth.
2. A more sustainable tax base, driven less by residential property valuation and more by commercial and industrial investment.
3. An economy that capitalizes on high-growth businesses and the creative individuals who fuel them, targeting specific industry classifications.
4. A commitment to “quality of place” throughout the community, including rising home values, new business startups, reduction of blighted areas, and the emergence of walkable corridors with a mixture of residential and commercial developments and related amenities.

This zoning request does not assist in high-wage job growth, is not a targeted high-growth industry, and the auto-oriented use does not contribute to walkable corridors.





Area Zoning Map

Applicant: DD White Settlement Property, LLC
 Address: 3201 White Settlement Road
 Zoning From: E
 Zoning To: Add Conditional Use Permit for car wash
 Acres: 0.50270355
 Mapsco: 62W
 Sector/District: Arlington Heights
 Commission Date: 1/12/2022
 Contact: 817-392-8190

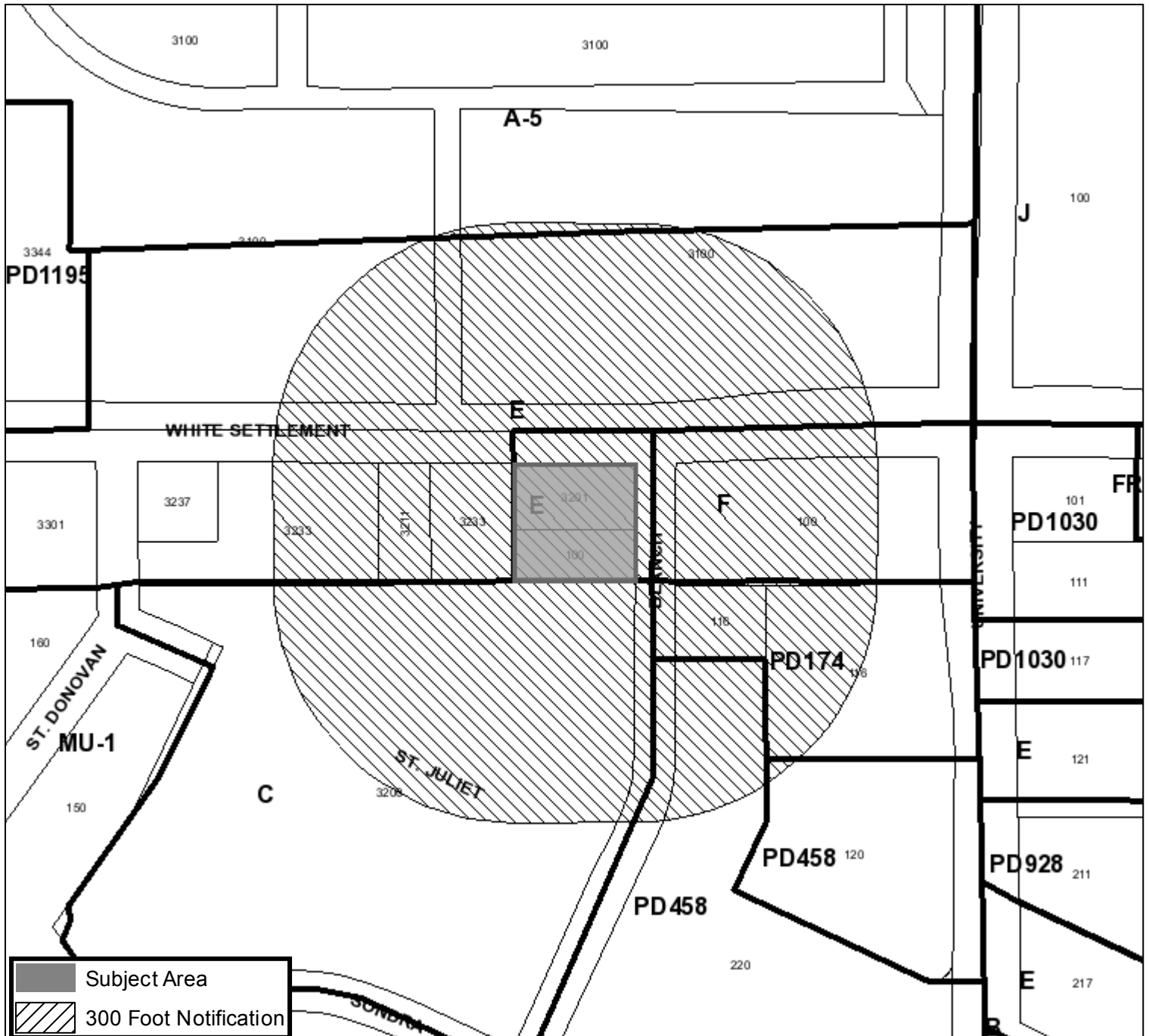

	Subject Area
	300 Foot Notification

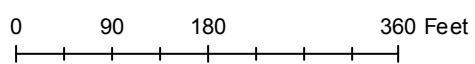

GENERAL NOTES

- CONTRACTOR SHALL VERIFY ALL EXISTING SITE AND BUILDING CONDITIONS IN THE FIELD PRIOR TO START OF ANY WORK. A REGISTERED SURVEYOR SHALL BE ENGAGED TO LAY OUT ALL SITE WORK.
- CONTRACTOR SHALL REVIEW DOCUMENTS AND NOTIFY THE ARCHITECT OF ANY DISCREPANCIES IN PROJECT PLANS AND SPECIFICATIONS, IN WRITING.
- DRAWINGS SHALL NOT BE SCALED FOR BIDDING AND/OR CONSTRUCTION PURPOSES.
- ALL PLAN DIMENSIONS ARE TO FINISHED FACE OF WALL UNLESS NOTED OTHERWISE.
- ALL CONSTRUCTION WORK SHALL MEET OR EXCEED ALL LOCAL, STATE AND NATIONAL BUILDING CODES, AND COMPLY WITH THE CITY OF FORT WORTH BUILDING ORDINANCES. A BUILDING PERMIT SHALL BE OBTAINED FROM THE CITY OF FORT WORTH.
- A LANDING MUST BE PROVIDED AT EACH EXIT DOOR. THE FLOOR SURFACE ON BOTH SIDES OF THE DOOR SHALL BE AT THE SAME ELEVATION AS PER THE TEXAS FIRE PREVENTION CODE.
- VERIFY ALL EXIT DOOR LOCKING HARDWARE COMPLIES WITH THE TEXAS FIRE PREVENTION CODE.
- ALL NEW CONCRETE FLOOR SLAB AREAS SHALL HAVE TERMIT TREATMENT.
- ALL STRUCTURES SHALL HAVE ADDRESS NUMBERS PLACED ON THE BUILDING IN ACCORDANCE WITH FORT WORTH MUNICIPAL CODE.
- ALL SIGNAGE, PERMANENT, PORTABLE, BANNERS, ETC. TO FOLLOW THE FORT WORTH SIGN ORDINANCE (CHAPTER 6).
- HOURS OF OPERATION:
CAR WASH - 7 DAYS A WEEK, 7:00 AM TO 8:00 PM.
- BUILDING NOT TO EXCEED 25'-0" IN HEIGHT AND TOWERS NOT TO EXCEED 35'-0" IN HEIGHT.
- EXTERIOR MATERIALS FOR BUILDING WILL BE STONE MASONRY, EIFS, ARCHITECTURAL WALL PANELS AND STOREFRONT TRANSLUCENT WINDOW PANELS.
- ALL DOMESTIC WATER SERVICE AND METER SHALL BE 1-1/2".
- VACUUM CANOPY IS 11'-0" IN HEIGHT (MAX). PAY STATION CANOPY IS 15'-0" IN HEIGHT (MAX). VACUUM CANOPIES AND PAY STATION CANOPY SHALL BE STEEL FRAMED WITH MASONRY WRAPS ON COLUMNS.
- APPLICANT WILL COMPLY WITH ALL LOCAL, STATE AND NATIONAL BUILDING CODES.
- THE CAR WASH ENCLOSES INTO THE NORTHERN SETBACK AND THE EASTERN PAY STATION ENCLOSES INTO EASTERN SETBACK. WILL APPLY FOR DEVELOPMENT WAIVER**
- 15 PARKING SPACES ARE REQUIRED FOR 3 CAR LENGTHS IN THE CAR WASH, INSTEAD OF 12 PARKING SPACES PROVIDED. WILL APPLY FOR A DEVELOPMENT WAIVER.**
- LIGHTING WILL CONFORM TO THE LIGHTING CODE. AND ALL LIGHTS WILL POINT AWAY FROM RESIDENTIAL PROPERTY.
- LANDSCAPING WILL COMPLY WITH SEC. 6.301 LANDSCAPING.
- SITE WILL COMPLY WITH SEC. 6.302 URBAN FORESTRY.
- 2 (TWO) EMPLOYEES PER SHIFT.
- 20' LANDSCAPE BUFFER ALONG WHITE SETTLEMENT RD. IS ENCLOSED BY BUILDING. DEVELOPMENT WAIVER IS BEING REQUESTED TO ALLOW 10' LANDSCAPE BUFFER AT FRONT AND 15.5' LANDSCAPE BUFFER AT REAR.**

Legal Description
0.53 Acre Tract

Lot 1, Block B, Westford
Joseph W. Conner Survey, Abstract No.355
City of Fort Worth, Tarrant County, Texas

*Being all of Lot 1, Block B, Westford, an addition to the City of Fort Worth, Tarrant County, Texas, according to the plat recorded in Volume 1808, Page 393, Plat Records, Tarrant County Texas, situated in the Joseph W. Conner Survey, Abstract No.355, City of Fort Worth, Tarrant County, Texas, being the 0.35 acre tract conveyed to DD White Settlement Property, LLC by deed recorded under County Clerk's File No.D216205870, Deed Records, Tarrant County, Texas and the 0.18 acre tract conveyed to said DD White Settlement Property, LLC by deed recorded under County Clerk's File No.D216233037, Deed Records, Tarrant County, Texas, being more particularly described as follows:
Beginning at a 1/2" iron rod with purple plastic cap stamped RPLS 5144 GO FROGS set for corner at the intersection of the south line of White Settlement Road and the west line of Blanch Circle, being the northeast corner of said Lot 1 and the northeast corner of said 0.35 acre tract;
Thence South 00°13'38" West with the west line of said Blanch Circle, passing a 3/4" iron rod found for the southeast corner of said 0.35 acre tract and the northeast corner of said 0.18 acre tract at a distance of 99.78 feet, continuing in all a distance of 149.88 feet to a 1/2" iron rod with purple plastic cap stamped RPLS 5144 GO FROGS set for corner, being the northeast corner of Lot AR, Block 4R, Westgate Addition, an addition to the City of Fort Worth, Tarrant County, Texas, according to the replat recorded in Cabinet A, Slide 2464, Plat Records, Tarrant County, Texas, the southeast corner of said 0.18 acre tract and the southeast corner of said Lot 1;
Thence North 89°50'15" West with the common line between said Lot AR and said Lot 1 a distance of 153.18 feet to a 1/2" iron rod with purple plastic cap stamped RPLS 5144 GO FROGS set for corner, being the southeast corner of Lot 2-A, Block B, Westford Addition, an addition to the City of Fort Worth, Tarrant County, Texas according to the replat recorded in Cabinet A, Slide 2687, Plat Records, Tarrant County, Texas and the southwest corner of said Lot 1;
Thence North 00°13'48" East with the common line between said Lot 2-A and said Lot 1, passing the northwest corner of said 0.18 acre tract and the southwest corner of said 0.35 acre tract at a distance of 49.89 feet, continuing in all a distance of 149.88 feet to a 3/4" iron rod found for corner in the south line of said White Settlement Road, being the northeast corner of said Lot 2-A, the northwest corner of said 0.35 acre tract and the northwest corner of said Lot 1;
Thence South 89°45'55" East with the south line of said White Settlement Road a distance of 153.18 feet to the POINT OF BEGINNING and containing 0.53 acres of land, more or less, as surveyed on the ground July 21, 2021 by Tucker Surveyors.*

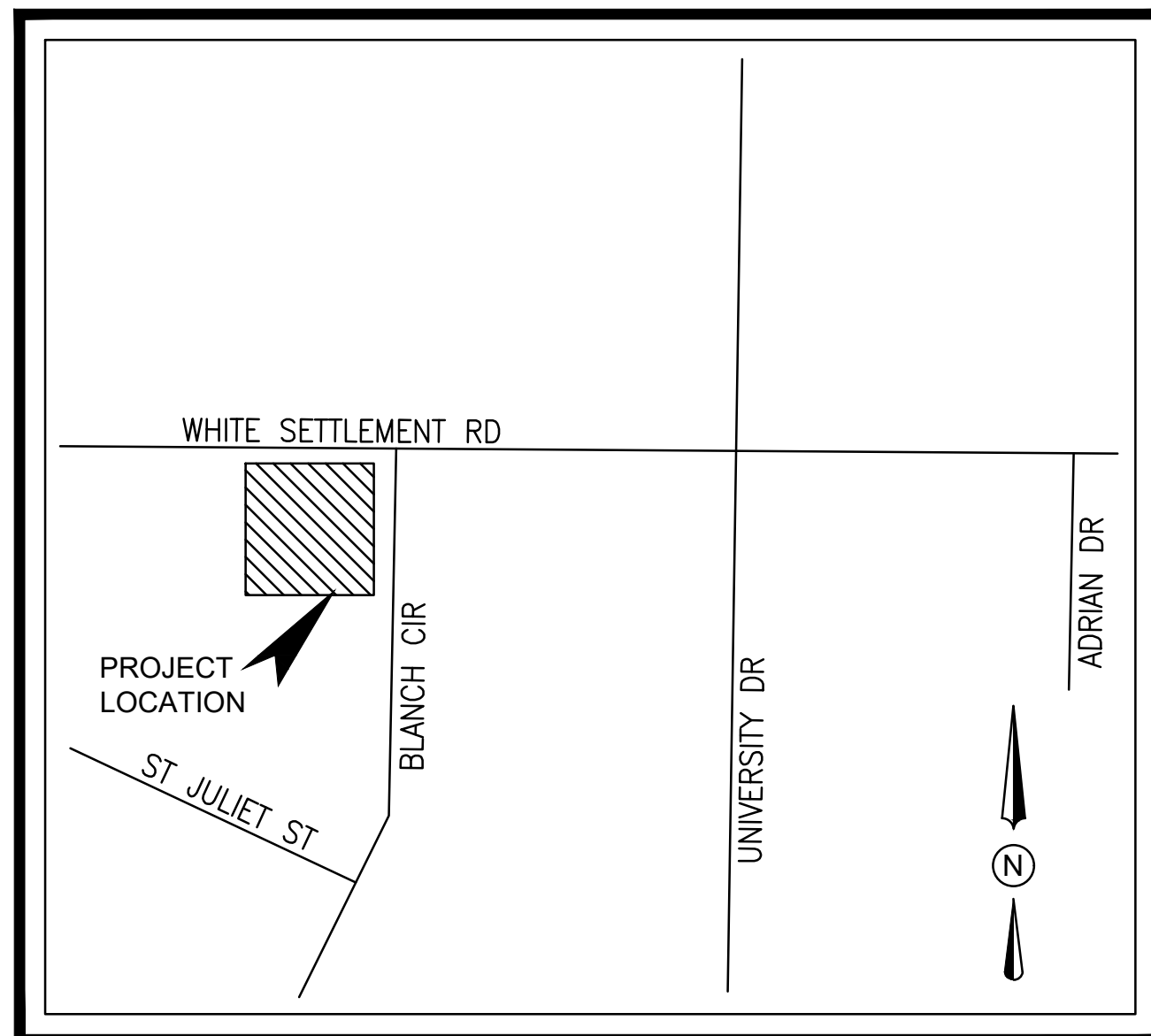

02 VICINITY MAP
NOT TO SCALE

01 SITE PLAN
SCALE: 1" = 20'-0"

ZONED: E

PAVEMENT LEGEND	
EXISTING CONCRETE	
PROPOSED CONCRETE	
PROPOSED LANDSCAPE	
PROPOSED SIDEWALK	

SITE DATA SUMMARY TABLE	
SITE ACREAGE:	0.53 ACRES (22,950 SQ. FT.)
ZONING:	E - NEIGHBORHOOD COMMERCIAL
PROPOSED USE:	CARWASH
BUILDING AREA:	3,486 S.F.
NUMBER OF STORIES:	1
BUILDING COVERAGE:	15%
FLOOR AREA RATIO:	0.15
IMPERVIOUS AREA:	17,178 S.F. (0.40 ACRES)
PERVIOUS/LANDSCAPE AREA:	5,772 S.F. (0.13 ACRES)
REGULAR PARKING PROVIDED:	0 SPACES
HANDICAP PARKING REQUIRED:	1 SPACE
HANDICAP PARKING PROVIDED:	1 SPACE
TOTAL PARKING PROVIDED:	1 SPACE
VACUUM STALLS PROVIDED:	11

DATE: 11.05.2021

JOB NO: XXXXX

DRAWN: STAFF

CHECKED: AG



AG DESIGN GROUP
PO BOX 383023
DUNCANVILLE, TX 75138



711 N. FIELDER RD.
ARLINGTON, TX 76012
PH: (817) 635-5696
FAX: (817) 635-5699

WHITE SETTLEMENT RD

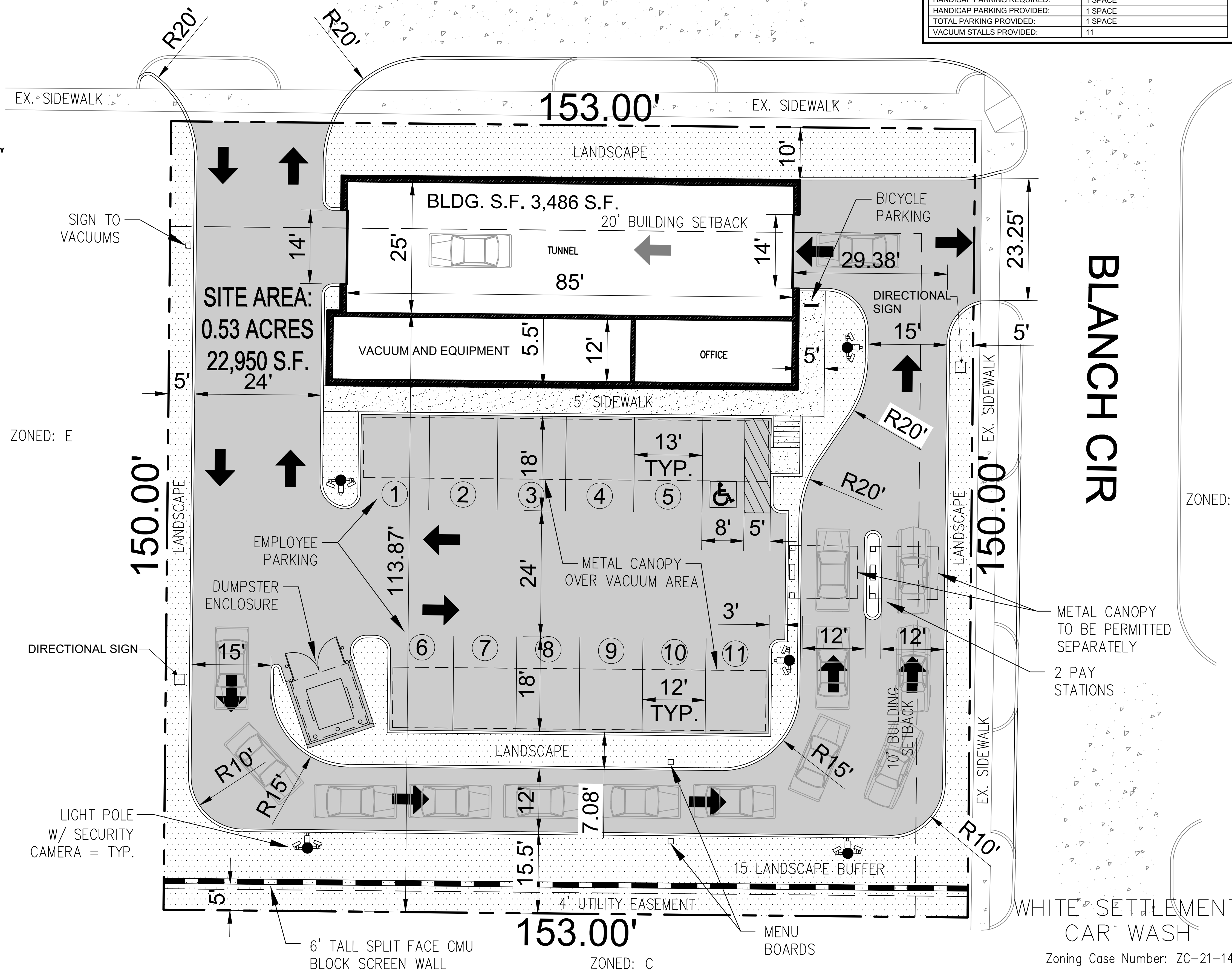

BLANCH CIR

ZONED: F

CLEANFREAK CAR WASH
WHITE SETTLEMENT RD.
& BLANCH CIR.
FORT WORTH, TX. 76107

REVISIONS

SITE PLAN

SHEET NUMBER

A1.00

Developer/Owner: Jake Petrie
Address: 780 W. Kennedale Parkway
City/State: Kennedale, Texas 76060
Telephone Number: 682.583.4962
E-mail Address: jake@cascadventures.com

Director of Planning and Development
Date: _____

Zoning Case Number: ZC-21-140





AG DESIGN GROUP, LLC
PO BOX 383023
DUNCANVILLE, TX 75138

CLEANFREAK CARWASH
WHITE SETTLEMENT RD. & BLANCH CIR.
FORT WORTH, TX 76107

REVISIONS

EXTERIOR ELEVATIONS

SHEET NUMBER

A5.03

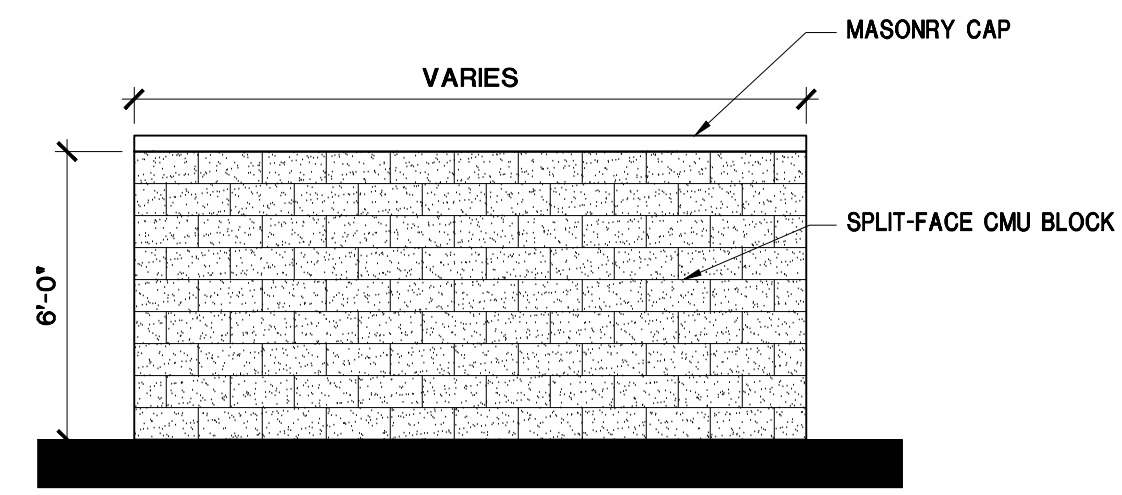

SCREENING FENCE
SCALE: 1/4"=1'-0"

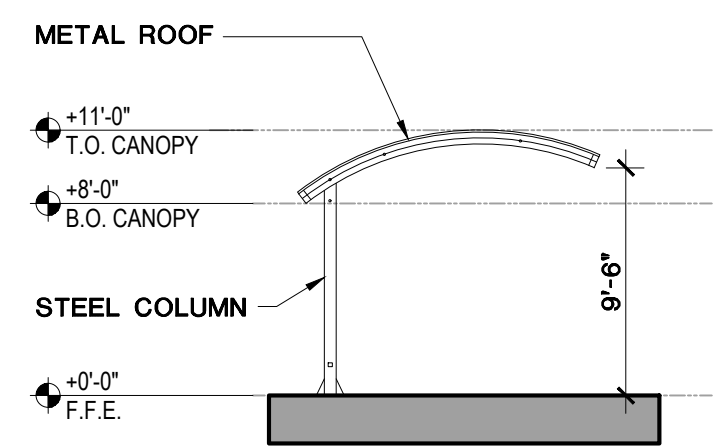

TYPICAL PAY STATION CANOPY FRONT VIEW
SCALE: 1/8"=1'-0"

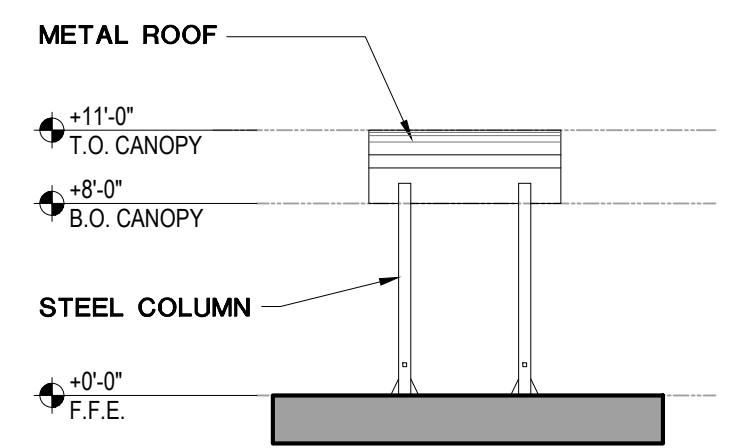

TYPICAL PAY STATION CANOPY SIDE VIEW
SCALE: 1/8"=1'-0"

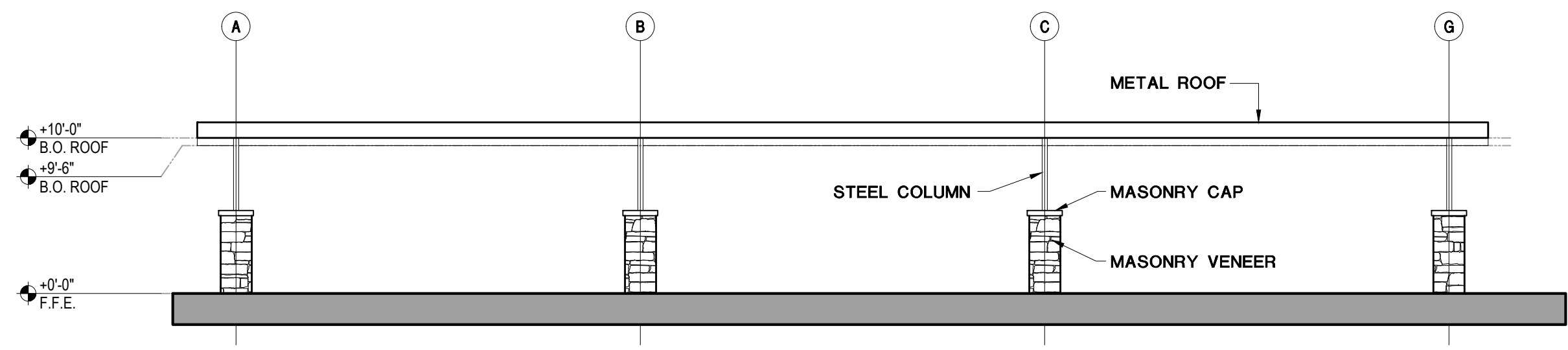

TYPICAL VACUUM CANOPY FRONT VIEW
SCALE: 1/8"=1'-0"

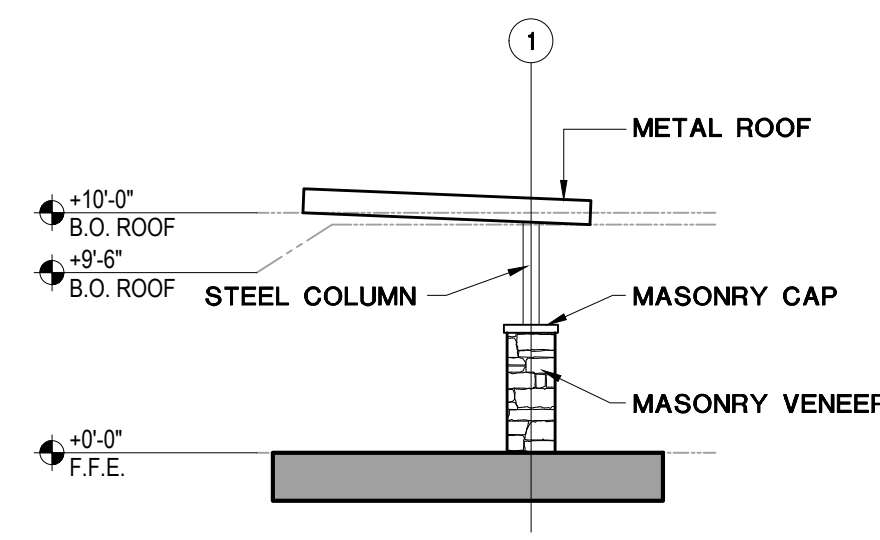

TYPICAL VACUUM CANOPY SIDE VIEW
SCALE: 1/8"=1'-0"

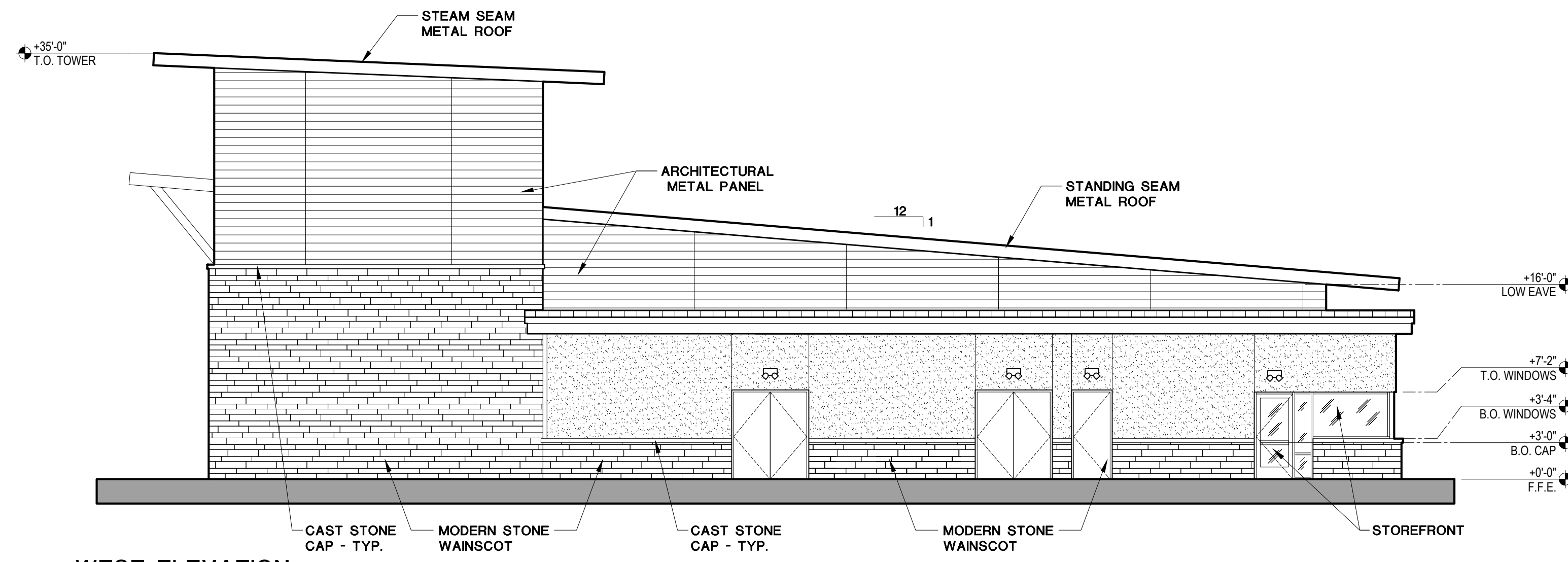

WEST ELEVATION
SCALE: 1/8"=1'-0"

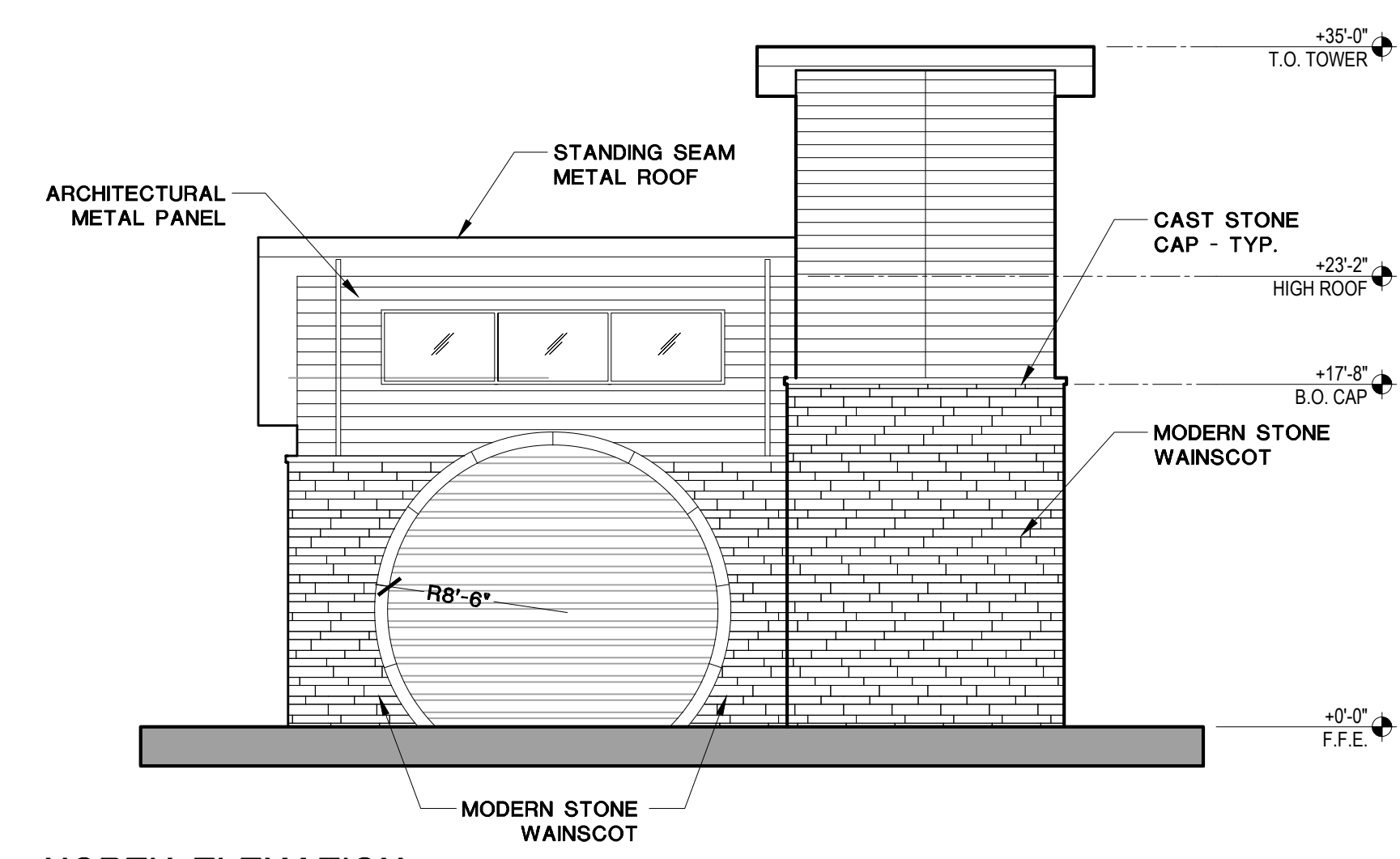

NORTH ELEVATION
SCALE: 1/8"=1'-0"

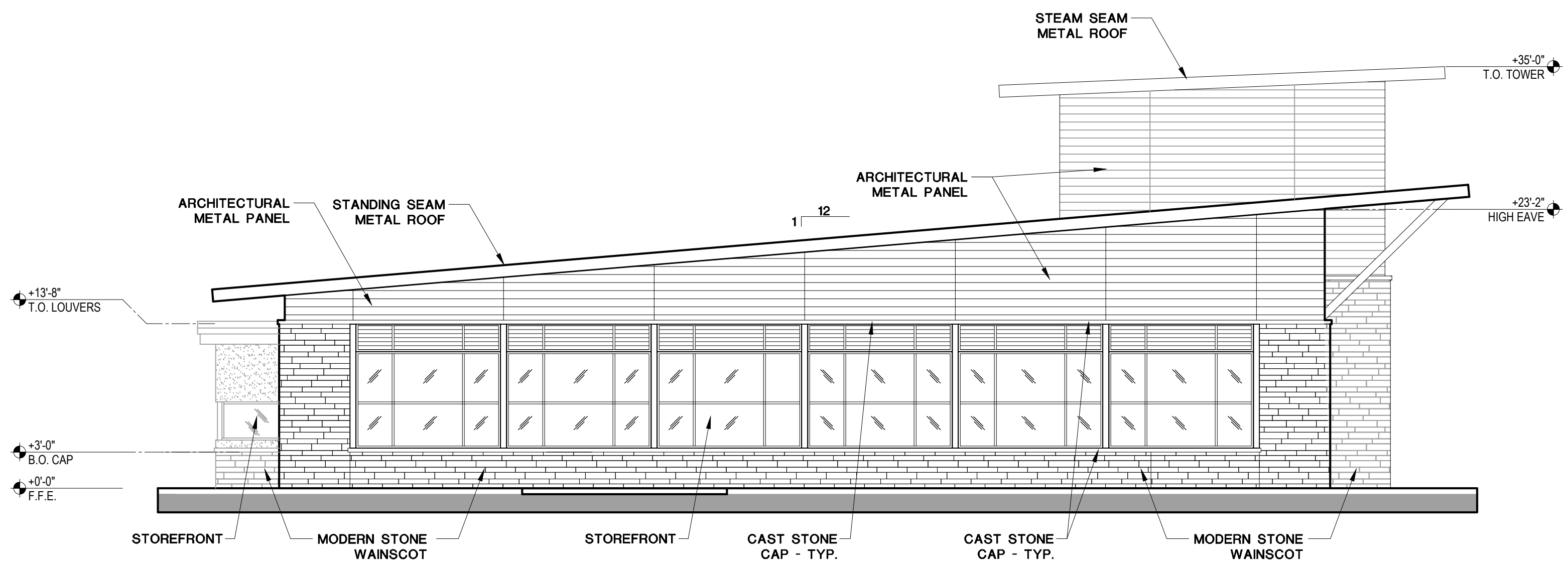

EAST ELEVATION
SCALE: 1/8"=1'-0"

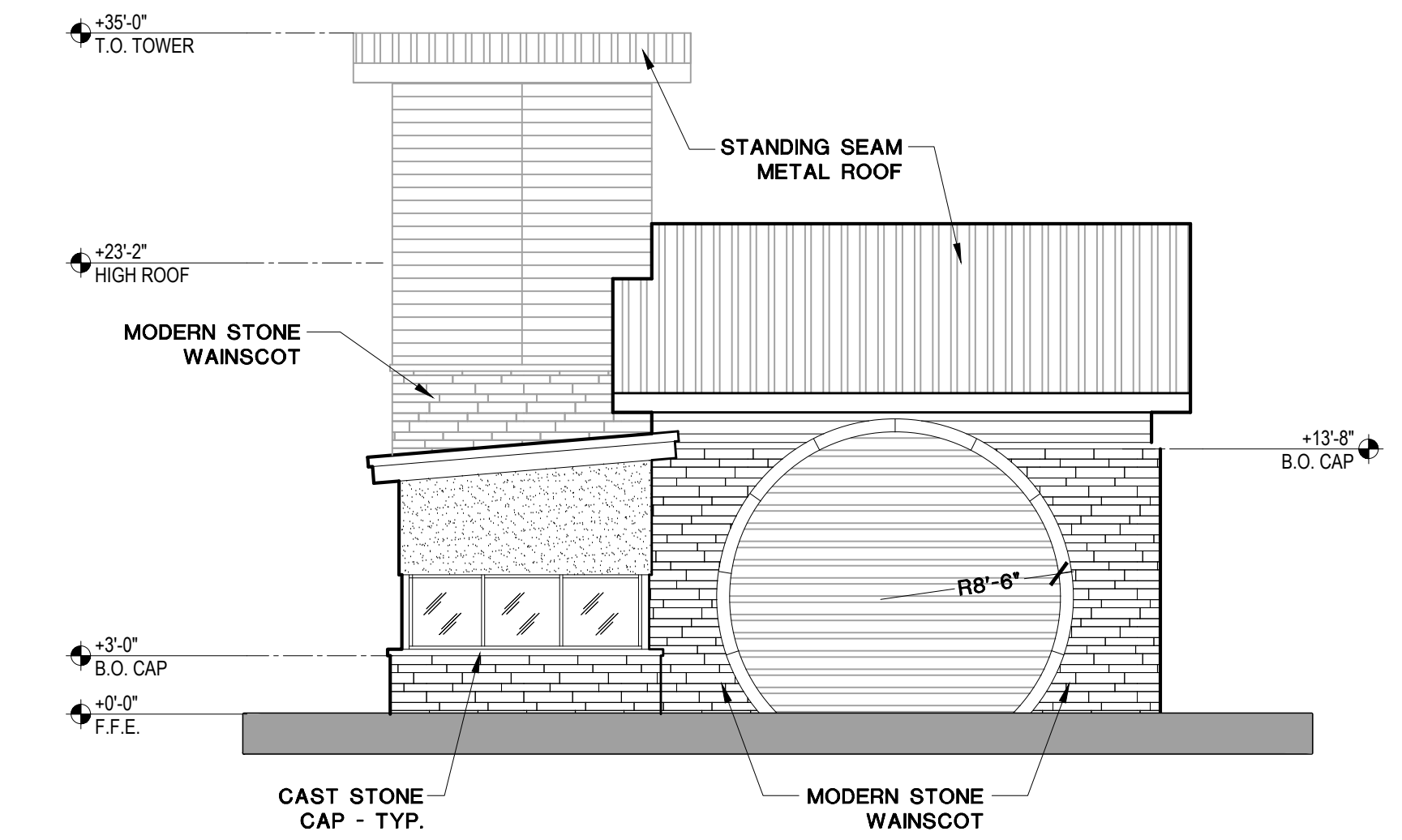

SOUTH ELEVATION
SCALE: 1/8"=1'-0"





Area Map



Council Districts





-  2 - Carlos E. Flores
-  3 - Michael D. Crain
-  4 - Cary Moon
-  5 - Gyna Bivens
-  6 - Jared Williams
-  7 - Leonard Firestone
-  8 - Chris Nettles
-  9 - Elizabeth M. Beck

Overlay Districts

-  Airport Overlay District
-  I-35W
-  TU PERIPHERAL
-  DESIGN DISTRICT
-  CONSERVATION DISTRICT

Noise Contours

DECIBEL

-  65
-  70
-  75
-  80
-  85

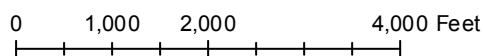

Future Land Use

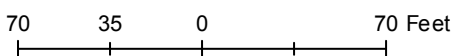
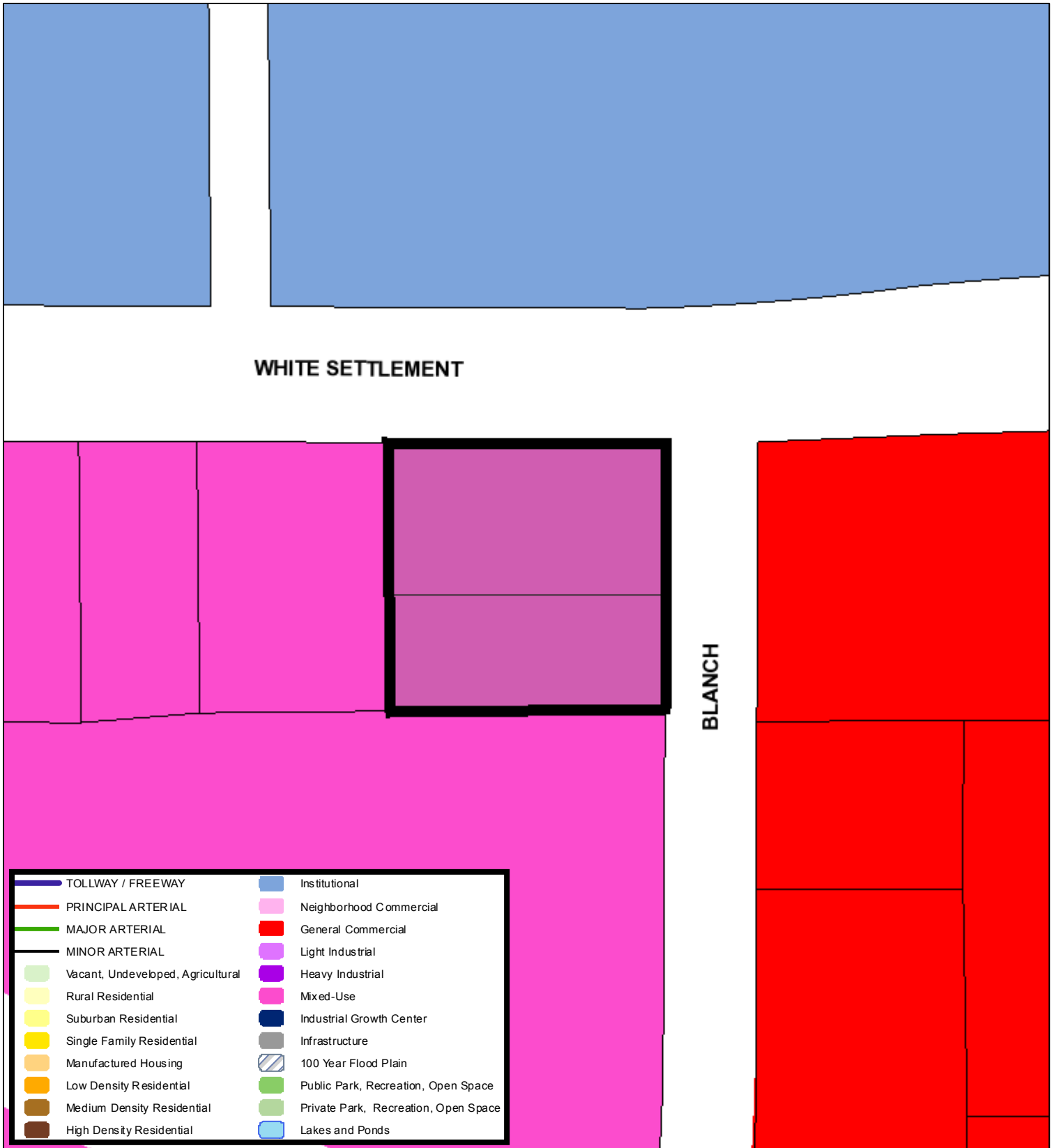

A Comprehensive Plan shall not constitute zoning regulations or establish zoning district boundaries. (Texas Local Government Code, Section 213.005.) Land use designations were approved by City Council on March 6, 2018.



Aerial Photo Map

