

ARCHITECT
5G Studio Collaborative, LLC.
800 Jackson St., Suite 500
Dallas, TX 75202
Kyle McCallahan

STRUCTURAL ENGINEER
McHale Engineering, Inc.
2000 Avenue G, Suite 800
Plano, TX 75074
Gary McHale

CIVIL ENGINEER
Winkelmann & Associates
6750 Hillcrest Plaza Dr. #215
Dallas, TX 75230



REV.	DATE	ISSUE TITLE

INCOMPLETE DOCUMENTS ARE FOR INTERIM REVIEW ONLY. NOT FOR REGULATORY APPROVAL, PERMIT OR CONSTRUCTION

VILLAGE CREEK DISTRIBUTION CENTER
5005 PARKER HENDERSON RD.
BUILDING RENDERING

DIM004 PROJECT NUMBER **A100** SHEET NUMBER

ARCHITECT
5G Studio Collaborative, LLC.
800 Jackson St., Suite 500
Dallas, TX 75202
Kyle McCluhan

STRUCTURAL ENGINEER
McHale Engineering, Inc.
2000 Avenue G, Suite 800
Plano, TX 75074
Gary McHale

CIVIL ENGINEER
Winkelmann & Associates
6750 Hillcrest Plaza Dr. #215
Dallas, TX 75230

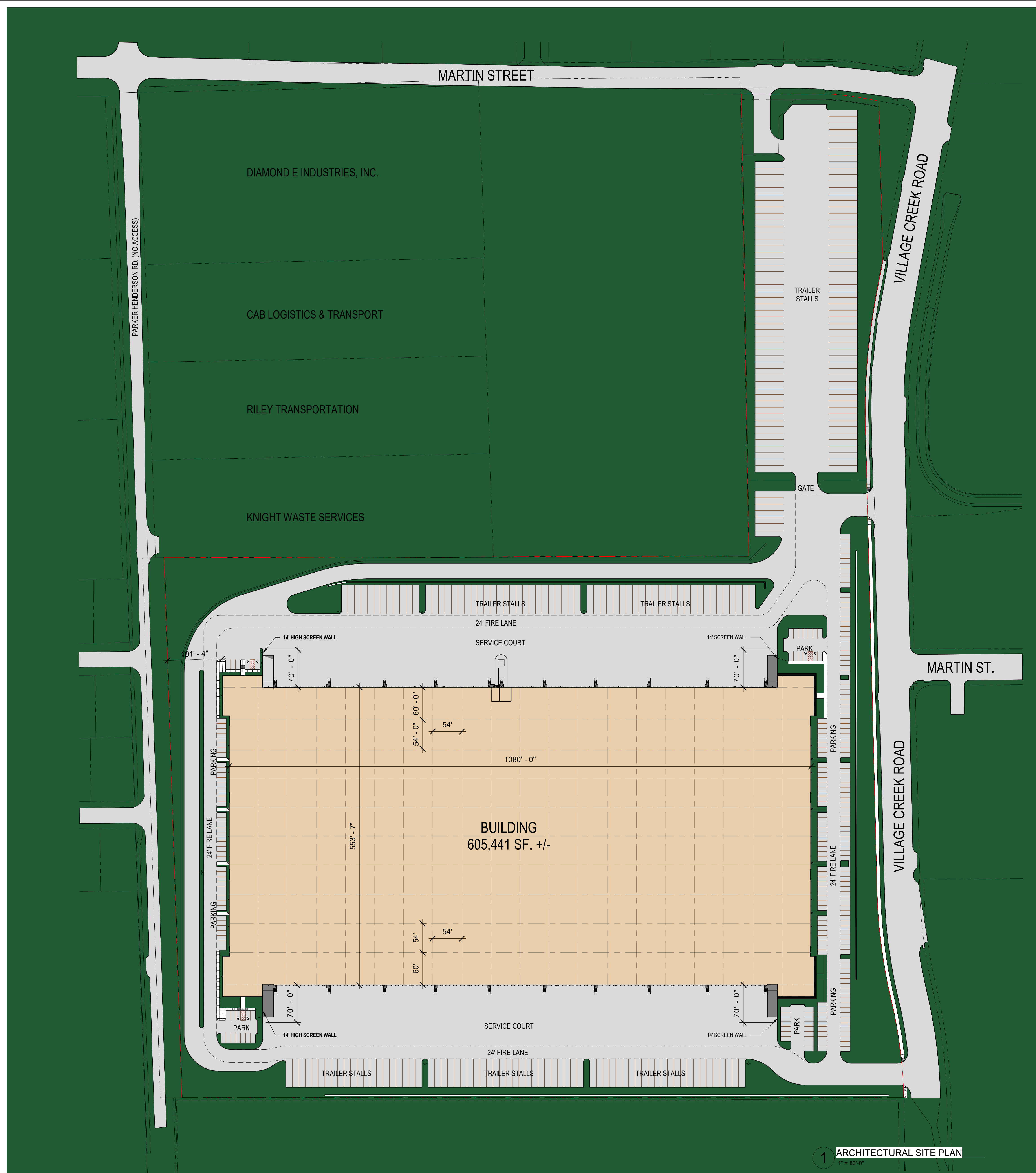

BUILDING INFORMATION
 BUILDING CONFIGURATION: SIDE LOADED
 BUILDING SF: 605,441 SF +/-
 SITE COVERAGE: 38.21%
 LAND AREA: 36.371 AC
 BUILDING DIMENSIONS: 553'-7" x 1080'
 ZONING: MEDIUM INDUSTRIAL
 CLEAR HEIGHT: 36' CLEAR
 BAY SPACING: 54' x 60' (SPEED BAY)
 54' x 54' (TYPICAL)
 AUTO PARKING COUNT: 251
 TRUCK STALLS COUNT: 242 STALLS
 DOCK HEIGHT DOOR COUNT: 113 DOORS
 GRADE LEVEL DOOR COUNT: 4 DOORS

REV.	DATE	ISSUE TITLE

INCOMPLETE DOCUMENTS ARE FOR INTERIM REVIEW ONLY. NOT FOR REGULATORY APPROVAL, PERMIT OR CONSTRUCTION

VILLAGE CREEK DISTRIBUTION CENTER
5005 PARKER HENDERSON RD.
ARCHITECTURAL SITE PLAN

DIM004 PROJECT NUMBER **A101** SHEET NUMBER

1 ARCHITECTURAL SITE PLAN
1" = 80'-0"

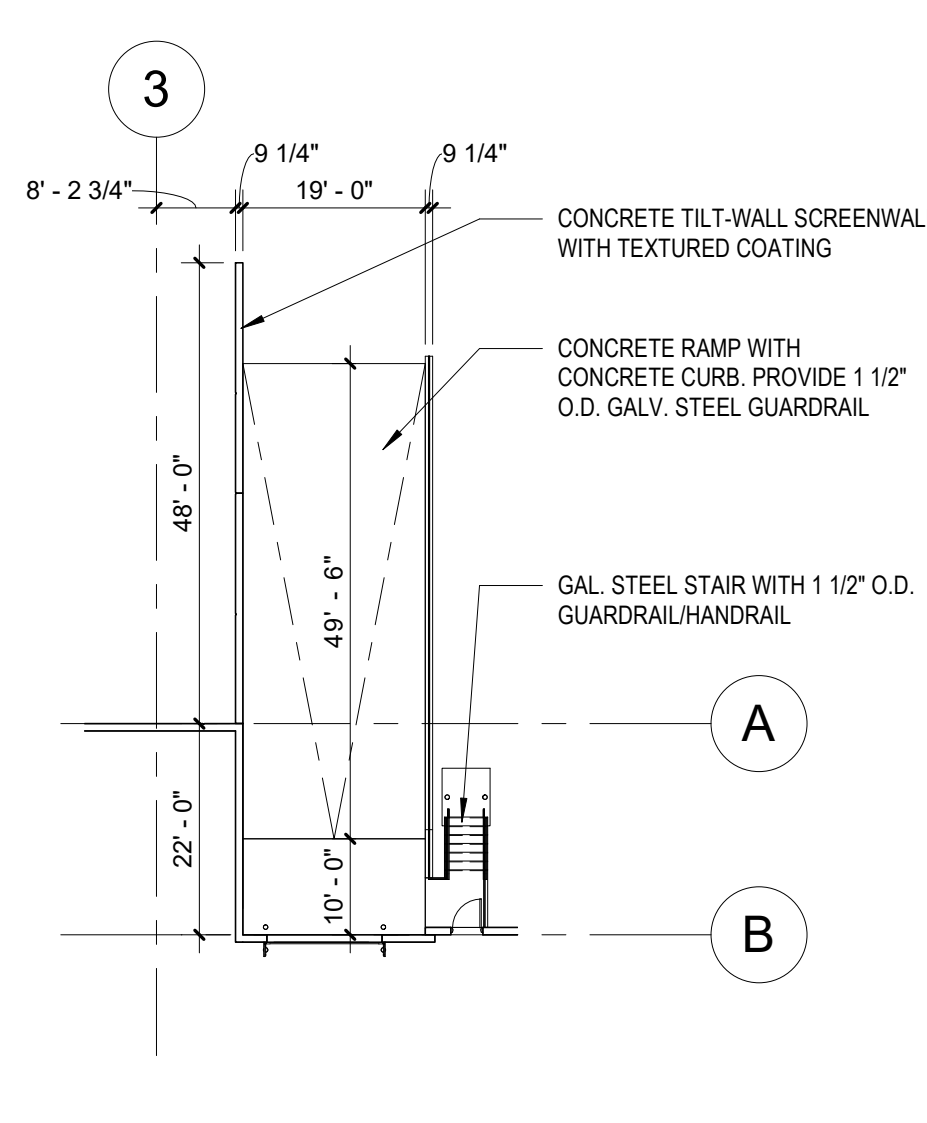
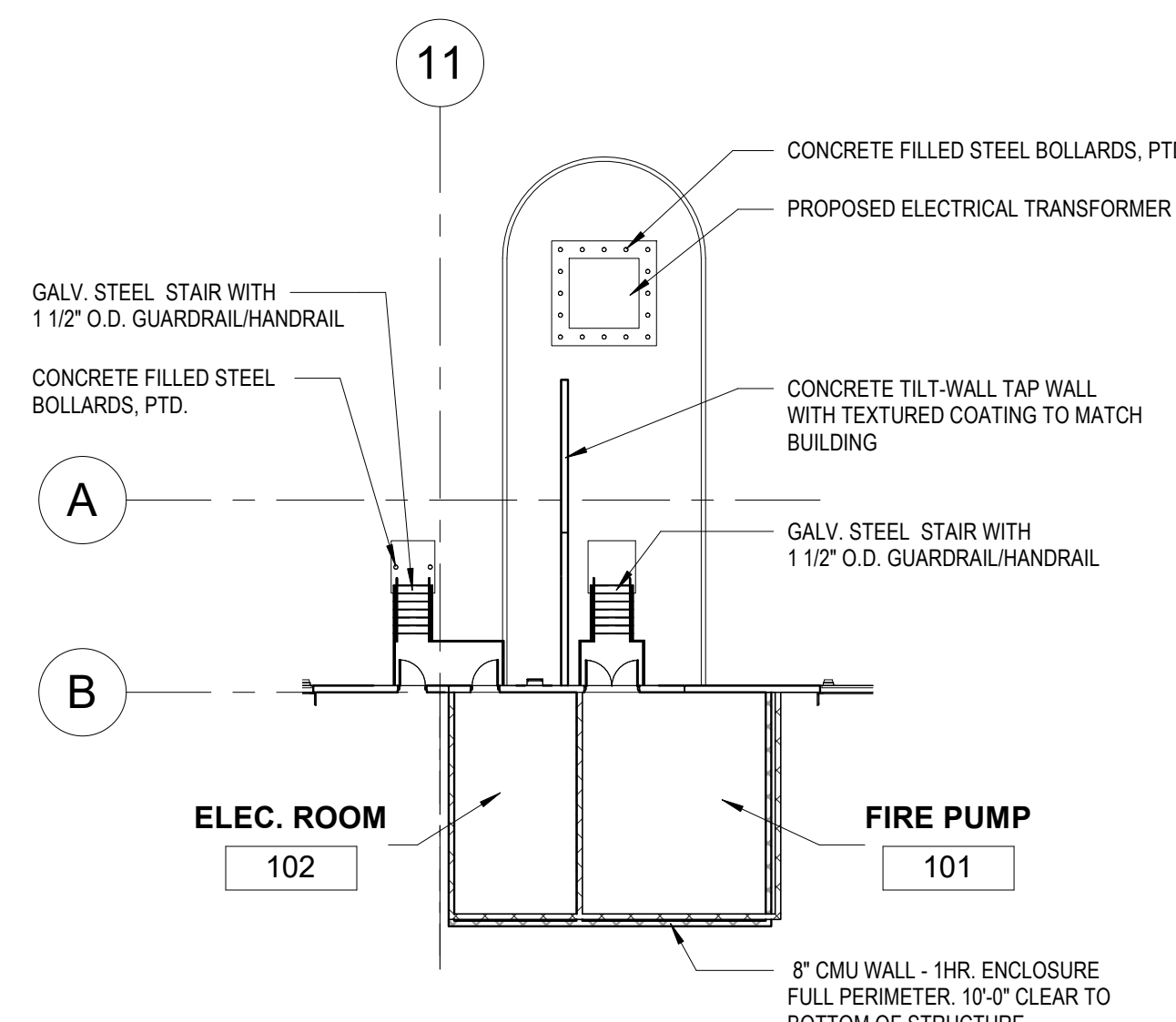
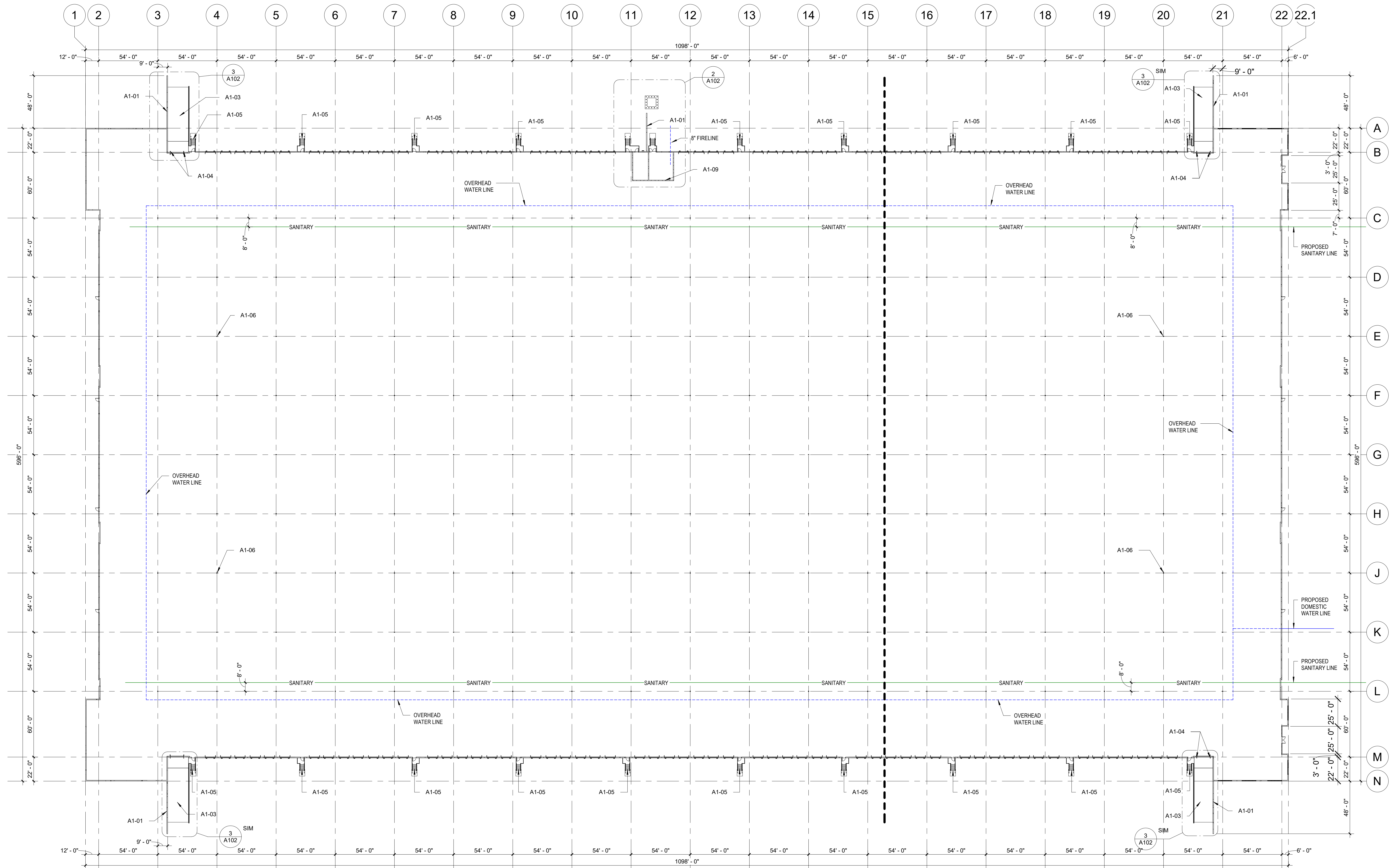

1 OVERALL FLOOR PLAN
1" = 40'-0"

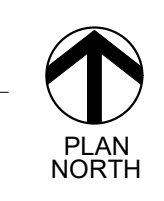

FLOOR PLAN - KEYNOTES	
A1-01	CONCRETE TILT-WALL SCREENWALL WITH TEXTURED COATING
A1-03	CONCRETE RAMP WITH 42" HIGH 1 1/2" O.D. GALV. STEEL GUARDRAIL
A1-04	6" DIAMETER CONCRETE FILLED GALV. STEEL BOLLARD - PTD.
A1-05	GALV. STEEL STAIR WITH 42" HIGH 1 1/2" O.D. GALV. STEEL GUARDRAIL/HANDRAIL
A1-06	STEEL COLUMN - REFER TO STRUCTURAL DRAWINGS
A1-09	8" CMU BLOCK WALL (1 HR RATED) - 10'-0" TO BOTTOM OF STRUCTURE. REFER TO STRUCTURAL

- GENERAL NOTES**
- PROVIDE 5' x 10' LEVEL AREA AT EACH ENTRY SET OF DOORS THAT IS LEVEL WITH NO SLOPE GREATER THAN 1:50 (2%) IN ANY DIRECTION, TYPICAL.
 - PROVIDE ONE HANDICAPPED PARKING SIGN PER EACH HANDICAPPED PARKING SPACE.
 - REFER TO SHEETS AXXX FOR DOOR SCHEDULE, DOOR TYPE AND HARDWARE.
 - REFER TO STRUCTURAL DRAWINGS FOR CONCRETE PANELS REINFORCING.
 - PROVIDE 15 MIL VAPOR BARRIER UNDER FLOOR SLAB AS SHOWN SHADED IN PLAN.
 - REFER TO SHEETS AXXX THROUGH AXXX FOR BUILDING ELEVATIONS.
 - ALL INSIDE FACES OF EXTERIOR TILT WALL PANELS SHALL BE PAINTED WHITE FROM FINISH FLOOR TO UNDERSIDE OF GIRDERS, TYPICAL. REFER TO SPECIFICATIONS.
 - ALL INTERIOR COLUMNS SHALL BE PAINTED SAFETY YELLOW FROM FINISH FLOOR TO 12'-0" AFF. THE REMAINDER OF THE COLUMN TO UNDERSIDE OF GIRDER SHALL BE PAINTED WHITE. REFER TO SPECIFICATIONS.

REV.	DATE	ISSUE TITLE

INCOMPLETE DOCUMENTS ARE FOR INTERIM REVIEW ONLY. NOT FOR REGULATORY APPROVAL, PERMIT OR CONSTRUCTION.

VILLAGE CREEK DISTRIBUTION CENTER
5005 PARKER HENDERSON RD.
Overall Floor Plan

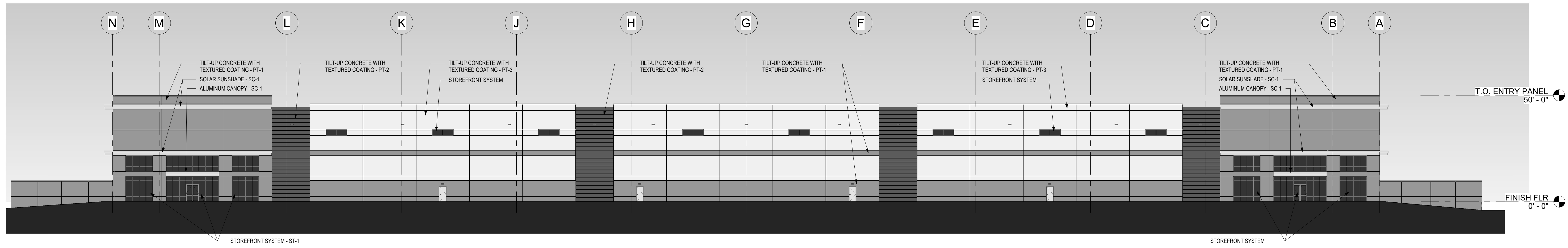

EAST ELEVATION - VILLAGE CREEK RD.

TOTAL AREA	27,875 SF	
TILT-UP PANELS	25,431 SF	91.23%
OPENING/GLAZING	2,444 SF	8.76%

1 EAST ELEVATION
3/64" = 1'-0"

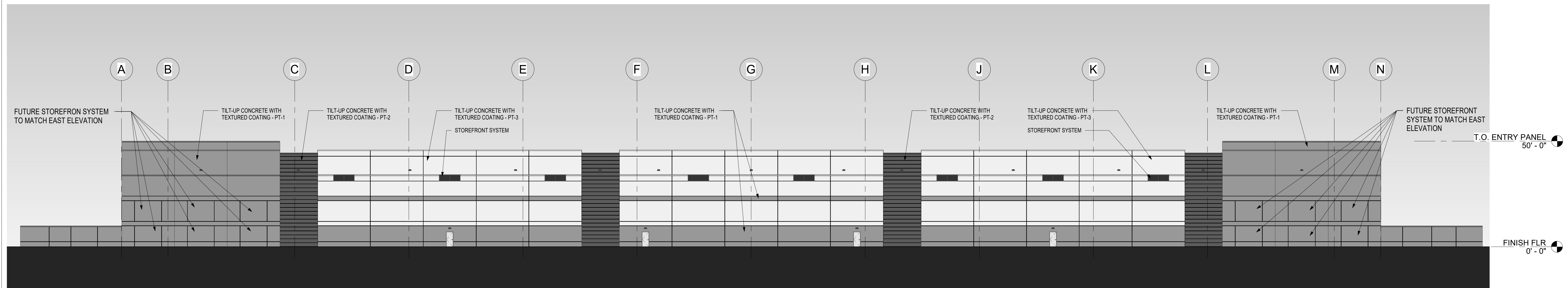

WEST ELEVATION - PARKER HENDERSON RD.

TOTAL AREA	27,875 SF	
TILT-UP PANELS	27,539 SF	98.8%
OPENING/GLAZING	336 SF	1.2%

2 WEST ELEVATION
3/64" = 1'-0"

ELEVATION FINISH SCHEDULE

- TEXTURED COATING - PT-1
- TEXTURED COATING - PT-2
- TEXTURED COATING - PT-3
- STOREFRONT - ST-1
- SOLAR SHADE / CANOPY - SC-1

REV.	DATE	ISSUE TITLE

INCOMPLETE DOCUMENTS ARE FOR INTERIM REVIEW ONLY. NOT FOR REGULATORY APPROVAL, PERMIT OR CONSTRUCTION

VILLAGE CREEK DISTRIBUTION CENTER
5005 PARKER HENDERSON RD.
EXTERIOR ELEVATIONS

DIM004 PROJECT NUMBER **A201** SHEET NUMBER

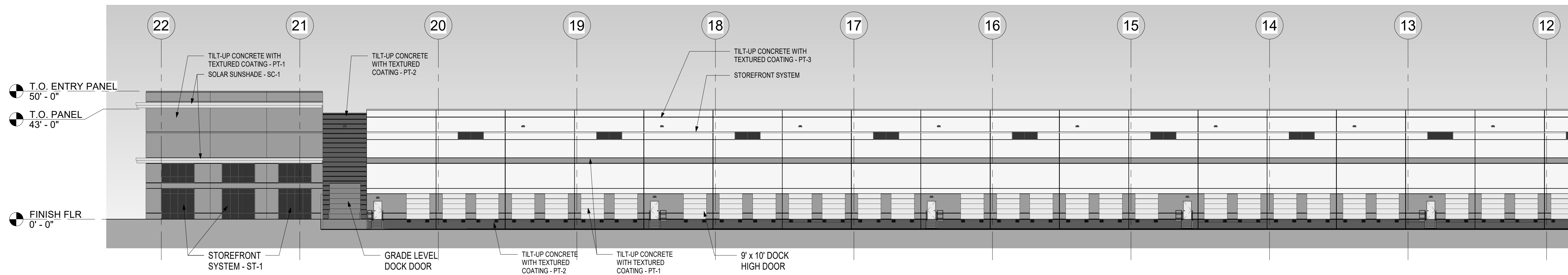

1 PARTIAL NORTH ELEVATION
3/84" = 1'-0"

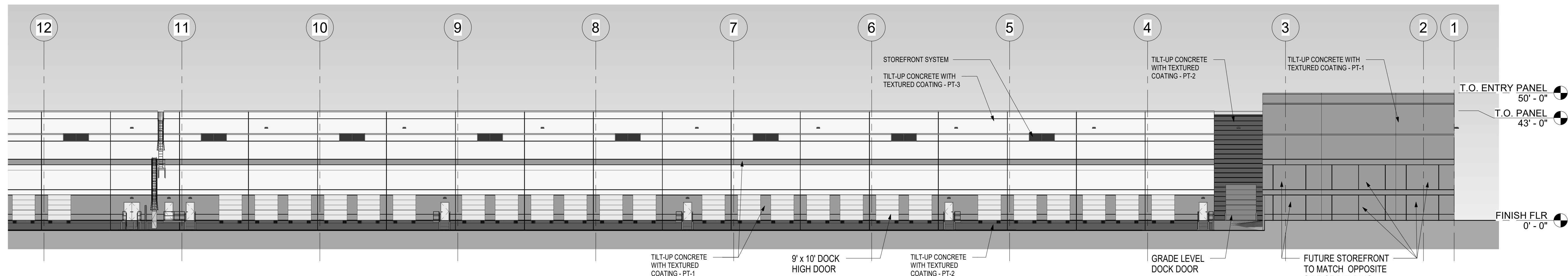

2 PARTIAL NORTH ELEVATION
3/84" = 1'-0"

NORTH ELEVATION - SCREENED SERVICE COURT

TOTAL AREA	54,831 SF	
TILT-UP PANELS	48,001 SF	87.54%
GLAZING	1,242 SF	2.27%
OPENING (DOORS)	5,588 SF	10.19%

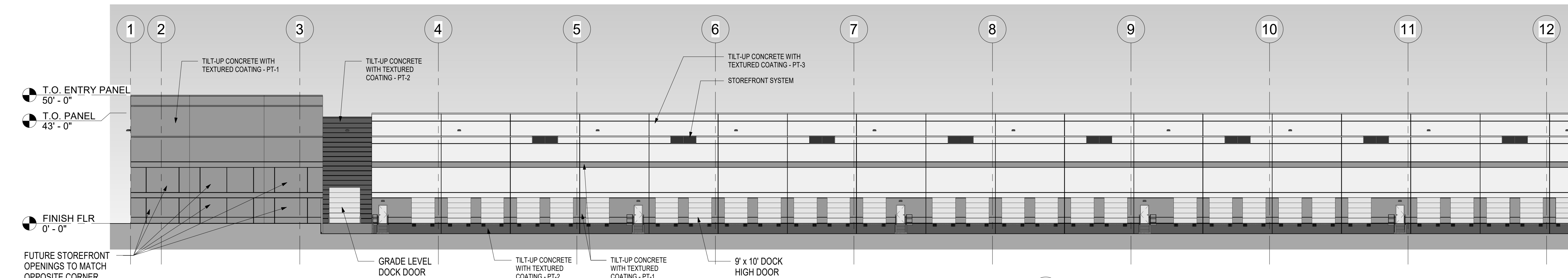

3 PARTIAL SOUTH ELEVATION
3/84" = 1'-0"

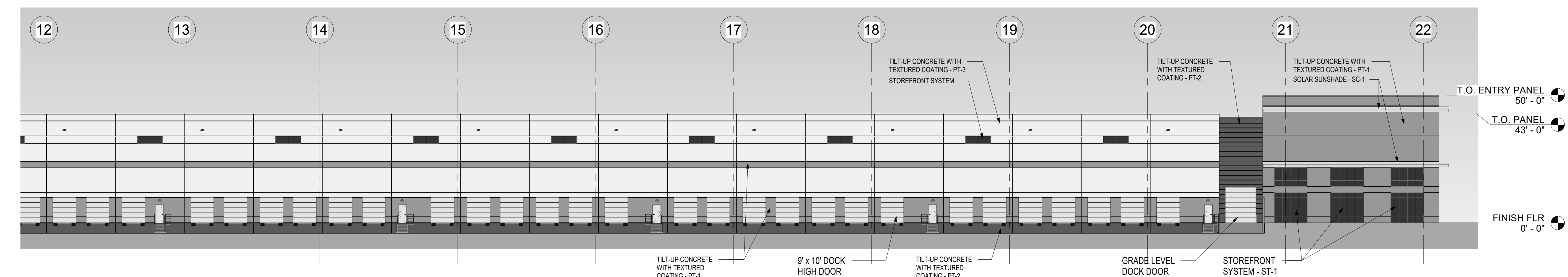

4 SOUTH ELEVATION - 2
3/84" = 1'-0"

SOUTH ELEVATION - SCREENED SERVICE COURT

TOTAL AREA	54,831 SF	
TILT-UP PANELS	47,799 SF	87.18%
GLAZING	1,242 SF	2.27%
OPENING (DOORS)	5,790 SF	10.55%

ELEVATION FINISH SCHEDULE

- TEXTURED COATING - PT-1
- TEXTURED COATING - PT-2
- TEXTURED COATING - PT-3
- STOREFRONT - ST-1
- SOLAR SHADE / CANOPY - SC-1

REV.	DATE	ISSUE TITLE

INCOMPLETE DOCUMENTS ARE FOR INTERIM REVIEW ONLY. NOT FOR REGULATORY APPROVAL, PERMIT OR CONSTRUCTION

VILLAGE CREEK DISTRIBUTION CENTER
5005 PARKER HENDERSON RD.
EXTERIOR ELEVATIONS

ARCHITECT
5G Studio Collaborative, LLC.
800 Jackson St., Suite 500
Dallas, TX 75202
Kyle McCallahan

STRUCTURAL ENGINEER
McHale Engineering, Inc.
2000 Avenue G, Suite 800
Plano, TX 75074
Gary McHale

CIVIL ENGINEER
Winkelmann & Associates
6750 Hillcrest Plaza Dr. #215
Dallas, TX 75230

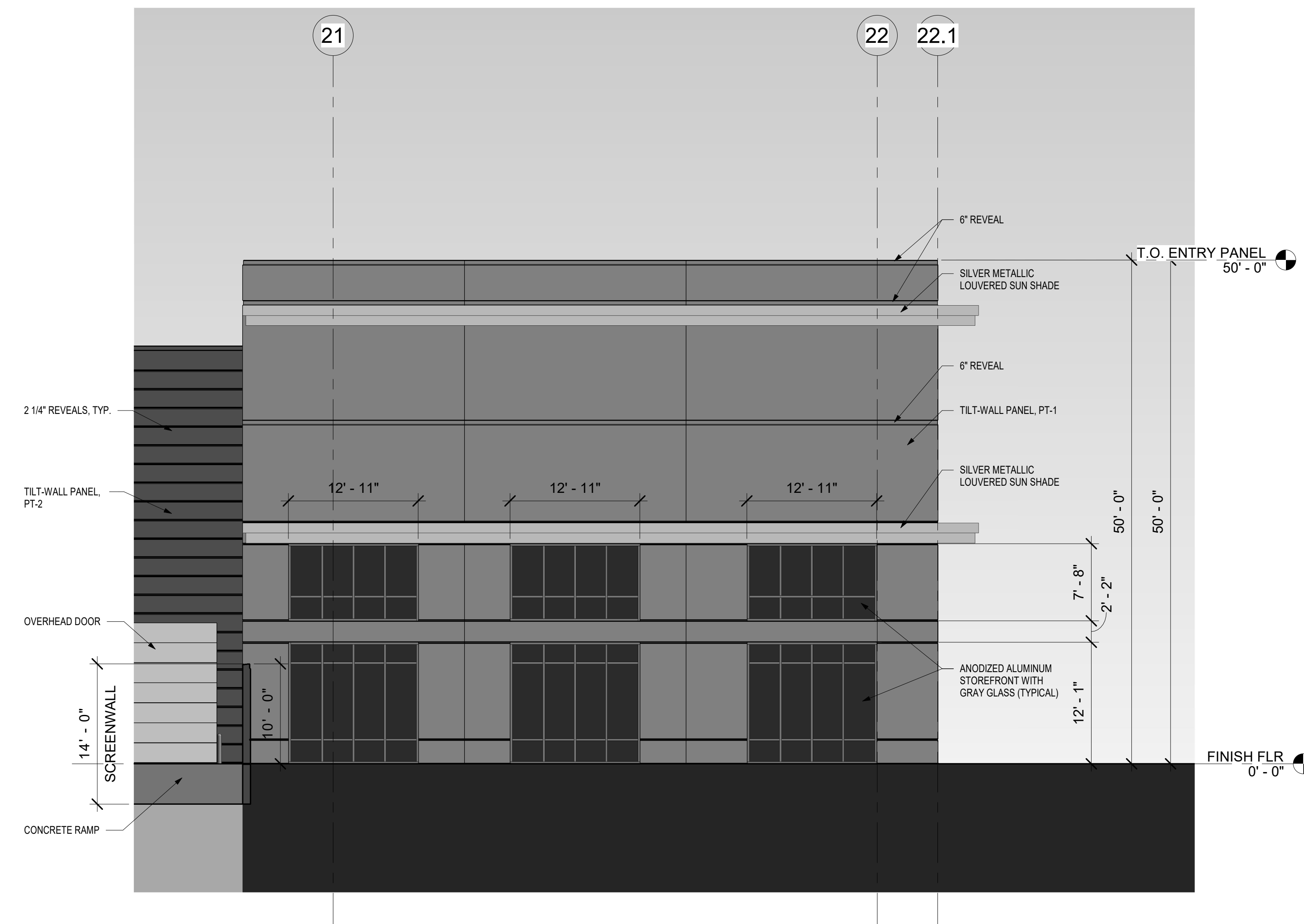

2 ENLARGED ELEVATION AT ENTRY
1/8" = 1'-0"

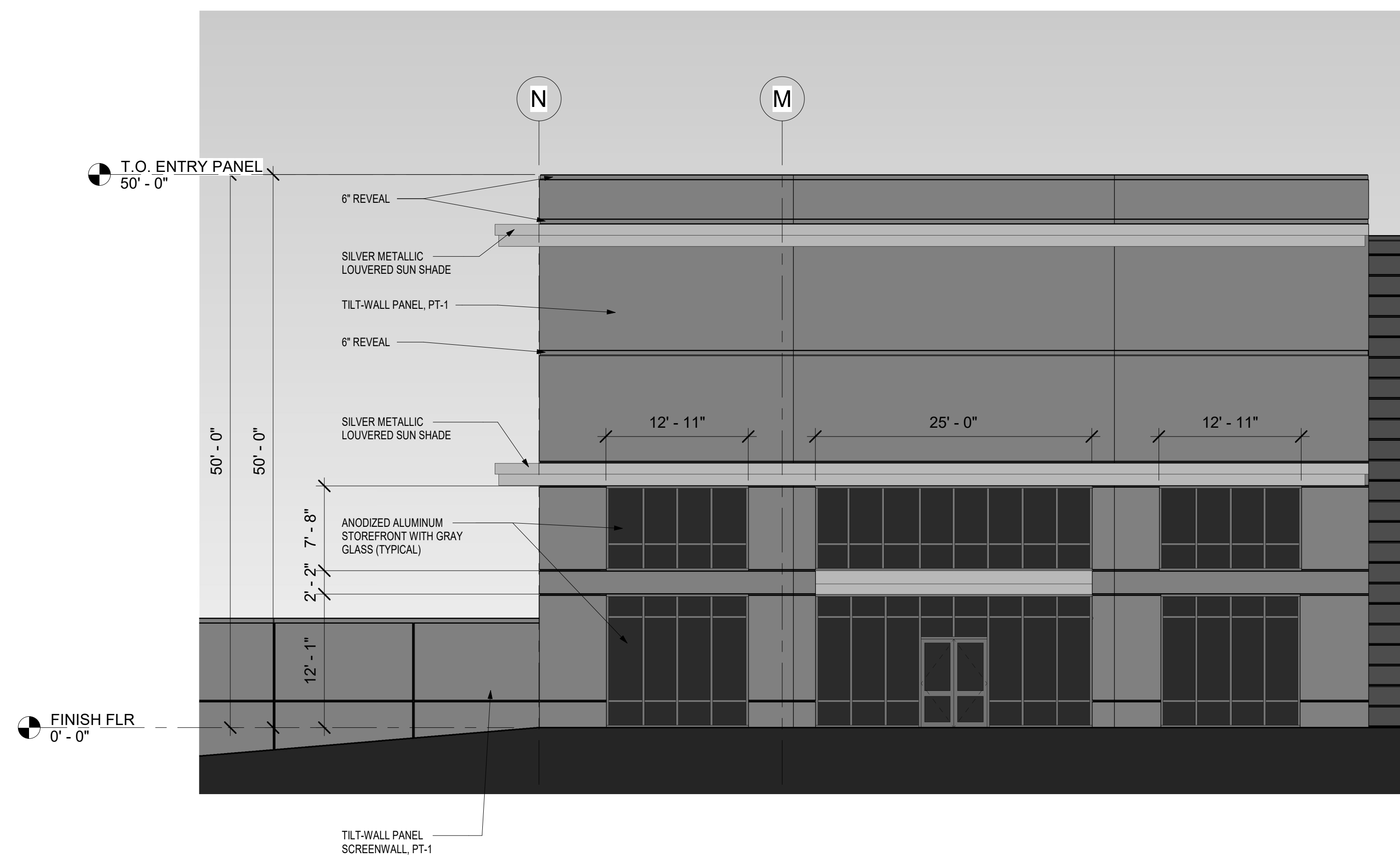

1 ENLARGED ELEVATION AT ENTRY
1/8" = 1'-0"

REV.	DATE	ISSUE TITLE

INCOMPLETE DOCUMENTS ARE FOR INTERIM REVIEW ONLY. NOT FOR REGULATORY APPROVAL, PERMIT OR CONSTRUCTION

VILLAGE CREEK DISTRIBUTION CENTER
5005 PARKER HENDERSON RD.
ENLARGED ENTRY ELEVATIONS

DIM004 PROJECT NUMBER **A203** SHEET NUMBER